



Tranquility® Low-Profile (TRL) Series

Models TRL 006 - 015 60Hz - HFC 410A

The Tranquility® TRL Series introduces the next generation in technology of commercial water source heat pumps. Its unmatched low-profile height

allows it to be installed in ceiling spaces as low as 12" in height. This space saving solution gives architects greater freedom when designing buildings. When compared to other horizontal water source heat pumps on the market, the TRL series allows building owners the ability to reduce floor to floor slab height saving money in construction materials.

Tranquility TRL products offer integrated water control options that save system watts by preventing over pumping both when the unit is in operation and when its not. ECM fan motors maximize the systems airflow movement efficiency. Advanced communicating controls offer reduced startup and commissioning time by providing an easy to read gateway into the system operating conditions. The low-profile product series design is paired with industry exclusive serviceability features along with many options for increased application flexibility and system efficiency.

Advantages of the TRL Series:

Standard Features:

- Available in sizes 006 (1/2 ton) through 015 (1.25 ton)
- **All sizes have a low 9" height cabinet design!**
- ECM Constant Torque fan motor
- Braze-plate heat exchanger
- iGate® Advanced Communicating Controls for reduced start up, commissioning and service time
- Nine standard safeties including water flow confirmation switch
- Integrally designed sound reducing attenuator box
- Unique double isolation compressor mounting for quiet operation
- Robust service tool connection located on the unit outside corner post
- Stainless steel drain pan
- 20 mesh water strainer

Configurable Options:

- Industry leading Ultra-Quiet sound attenuation package
- Auto flow regulators that limit water flow to the unit preventing system over pumping
- Two-way motorized water valves that prevent water flow through the unit when it is not in operation increasing system pumping efficiency
- Corrosive resistant Tin-plated or E-coated air coils
- Internally mounted water pump for single pipe systems
- Robust high pressure flow switch for system loop pressure designs above 160 psi
- BACnet, Modbus and Johnson N2 compatibility options for DDC controls
- Bottom access unit integrated power disconnect
- 2" Filter Frame to support higher indoor air quality filters

ASHRAE/AHRI/ISO 13256-1 English (I-P) Units

Model	Water Loop Heat Pump			
	Cooling 86°F		Heating 68°F	
	Capacity Btuh	EER Btuh/W	Capacity Btuh	COP
TRL006	6400	15.0	7400	4.5
TRL009	8800	15.0	10300	4.5
TRL012	12100	15.0	13500	4.5
TRL015	14000	14.7	15100	4.5

Cooling capacities based upon 80.6°F DB, 66.2°F WB entering air temperature
 Heating capacities based upon 68°F DB, 59°F WB entering air temperature
 All ratings based upon operation at lower voltage of dual voltage rated models

Tested To ARI-260 - Ducted Discharge

Model	Mode	NC	dBa
TRL006	Cooling - Low Fan Speed	30	46.3
TRL009		33	46.9
TRL012		35	51.5
TRL015		34	51.0

Octave Band Sound Power Level (dB re 1pW)
 Ultra-Quiet Construction

Unit Dimensions

Model	Overall Cabinet (in)		
	Width	Depth	Height
TRL006-015	22.5	53	9

Bottom Service Access:

- Controls/Electrical Components
- Water Circuit/Components
- Refrigerant Circuit/Components
- Power Disconnect
- Service Tool Connection
- Drain Pan Servicing & Removal
- Air Coil
- Air Filter
- Blower Motor Assembly
- Water Strainer

LEFT RETURN BOTTOM ISO VIEW

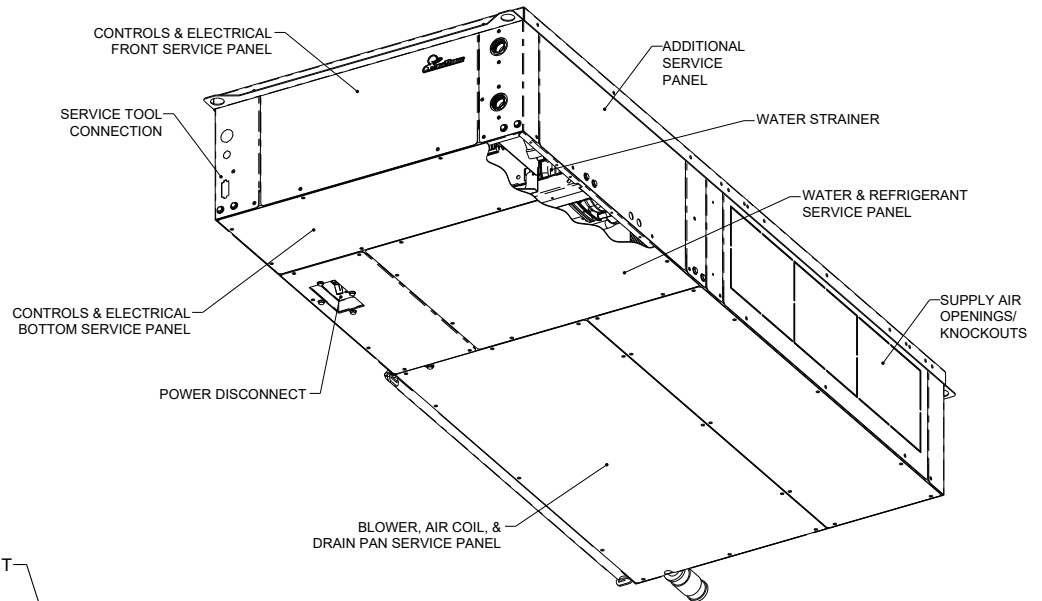

FRONT

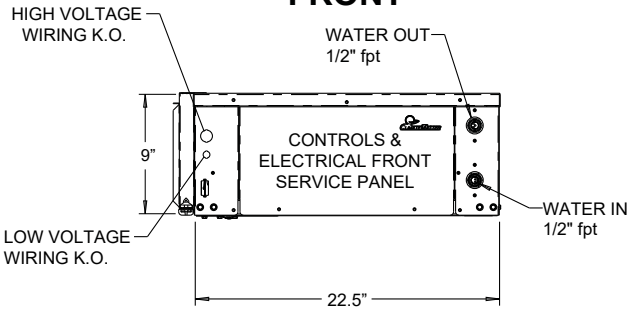

REAR

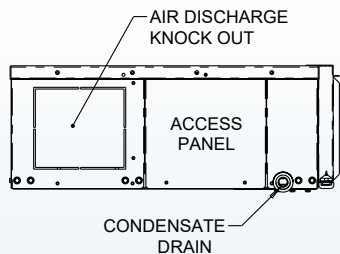

LEFT

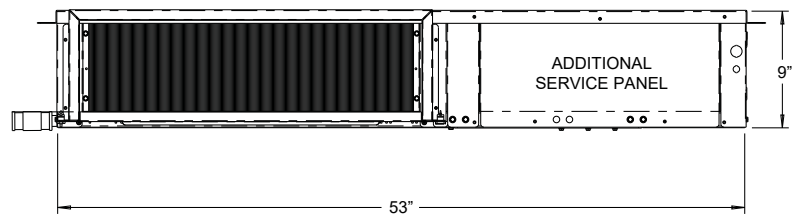

7300 S.W. 44th Street
 Oklahoma City, OK 73179
 Phone: 405-745-6000
climatemaster.com